

Answers:

(1) $v = 3.0 \times 10^{10}$ Hz, $E = 2.0 \times 10^{-23}$ J

(2) $\lambda = 323$ m, $E = 6.2 \times 10^{-28}$ J

(3) $v = 6.66 \times 10^{14}$ Hz, $\lambda = 4.51 \times 10^{-7}$ m

(4) $v = 1.10 \times 10^{15}$ Hz, $\lambda = 2.73 \times 10^{-7}$ m

(5) $E_2 = -5.445 \times 10^{-19}$ J, $E_2 = -2.178 \times 10^{-18}$ J, $E_{2,1} = 1.6345 \times 10^{-18}$ J, $v = 2.465 \times 10^{15}$ Hz, $\lambda = 1.22 \times 10^{-7}$ m

(6) $E_5 = -8.712 \times 10^{-20}$ J, $E_3 = -2.420 \times 10^{-19}$ J, $E_{5,3} = 1.549 \times 10^{-19}$ J, $v = 2.337 \times 10^{14}$ Hz, $\lambda = 1.283 \times 10^{-7}$ m

(7) (a) 3p (b) 2s (c) 5f (d) 4d

(8) (a) not allowed, if $n = 2$ the maximum value of l is 1 (b) allowed
(c) not allowed, if $l = 1$, the maximum value of m_l is 1 (d) allowed

(9) (a) 3 (b) 5 (c) 2 (d) 9 (e) 16

(10) (a) 2 (b) 6 (c) 2 (d) 2 (e) 14

(11) (a) 32 (b) 10 (c) 6 (d) 9

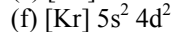
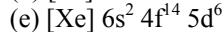
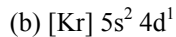
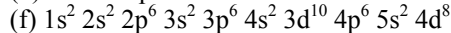
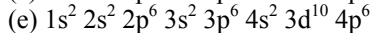
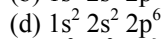
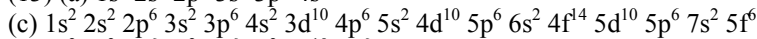
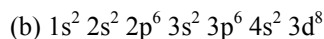
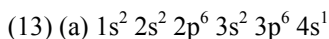
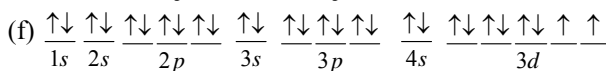
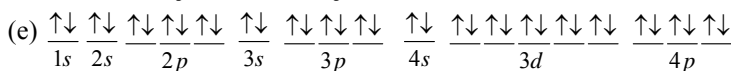
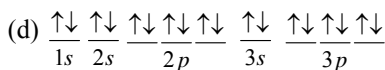
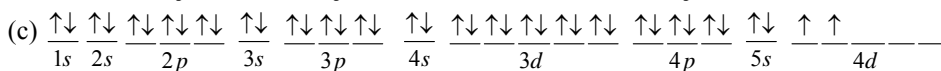
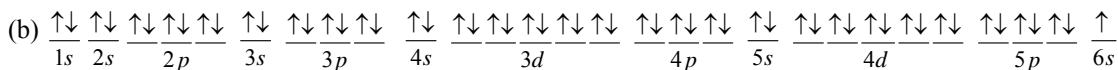
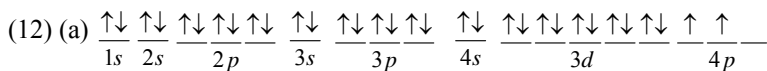

(15) ground: $1s^2 2s^2 2p^4$ excited: $1s^2 2s^2 2p^3 3s^1$ or $1s^2 2s^2 2p^3 3p^1$ (answers will vary)

(16) (a) neon: $1s^2 2s^2 2p^6$ (b) iron: $1s^2 2s^2 2p^6 3s^2 3p^6 4s^2 3d^6$ (c) cadmium: [Kr] $5s^2 4d^{10}$

Name: _____
Period: _____

Periodic Trends

- (1) List each set of atoms/ions from smallest to largest radius.
(a) Mg, Be, Ca (b) C, B, N
(c) Li^+ , K^+ , Na^+ (d) P^{3-} , As^{3-} , N^{3-}
(e) Cs, Sr, Si, O (f) Al, B, Ca, Mg
- (2) Which of the elements listed has the highest first ionization energy?
(a) K, Li, Na (b) C, O, Be
(c) Na, Cl, Al (d) Ba, Ca, Be
- (3) Which of the elements listed has the highest electronegativity?
(a) O, N, F (b) Se, O, S
(c) I, Br, Cl (d) Mg, Si, S
- (4) Complete the following table:

	(a) P or Cl?	(b) F or Br?
Which element has a larger atomic radius? Explain.		
Which element has a higher ionization energy? Explain.		
Which element has a higher electronegativity? Explain.		

- (5) Which has a larger radius, the neutral atom or the ion? Explain.
(a) F or F^- (b) Mg or Mg^{2+}
- (6) Order the following ions from smallest to largest: Sc^{3+} , P^{3-} , Ca^{2+} , S^{2-} , K^+ , Cl^-

Answers:

(1) (a) $\text{Be} < \text{Mg} < \text{Ca}$ (b) $\text{N} < \text{C} < \text{B}$ (c) $\text{Li}^+ < \text{Na}^+ < \text{K}^+$, (d) $\text{N}^{3-} < \text{P}^{3-} < \text{As}^{3-}$ (e) $\text{O} < \text{Si} < \text{Sr} < \text{Cs}$ (f) $\text{B} < \text{Al} < \text{Mg} < \text{Ca}$

(2) (a) Li (b) O (c) Cl (d) Be

(3) (a) F (b) O (c) Cl (d) S

(4)

	(a) P or Cl?	(b) F or Br?
Which element has a larger atomic radius? Explain.	- atomic radius decreases across a row - since Cl has more protons than P, the nucleus of Cl has a greater attractive force than the nucleus of P and therefore pulls its electrons in more tightly and P has a larger atomic radius than Cl	- atomic radius increases down a group - since Br has valence electrons with $n=4$ and F has valence electrons with $n=2$ F has a larger atomic radius than Br
Which element has a higher ionization energy? Explain.	- IE increases across a row - since Cl has more protons than P, the electrons of Cl are held more tightly than P and Cl has a higher IE than P	- IE decreases down a group - since electrons of Br are further away from the attractive force of the nucleus than electrons of F they are easier to remove and F has a higher IE than Br
Which element has a higher electronegativity? Explain.	- EN increases across a row - since Cl is a smaller atom than P, atoms in a bond are in closer proximity to the attractive force of the nucleus and Cl has a higher EN than P	- EN decreases down a group - since F is a smaller atom than Br, atoms in a bond are in closer proximity to the attractive force of the nucleus and F has a higher EN than Br

(5) (a) $\text{F} < \text{F}^-$ When the F^- ion is formed electrons are gained so the anion is larger than the neutral atom.

(b) $\text{Mg} > \text{Mg}^{2+}$ When the Mg^{2+} ion is formed electrons are lost so the cation is smaller than the neutral atom.

(6) $\text{Sc}^{3+} < \text{Ca}^{2+} < \text{K}^+ < \text{Cl}^- < \text{S}^{2-} < \text{P}^{3-}$

Name: _____
Period: _____

Bonding

(1) Draw a Lewis structure for each of the following molecules.

- | | |
|---------------------------|---------------------|
| (a) SiO_2 | (l) SeO_3 |
| (b) SiH_4 | (m) SbCl_5 |
| (c) NBr_3 | (n) BeF_2 |
| (d) ClF_5 | (o) IF_5 |
| (e) Cl_2O | (p) CF_4 |
| (f) PF_5 | (q) SF_2 |
| (g) BH_3 | (r) SeF_6 |
| (h) IF_3 | (s) PCl_3 |
| (i) SCl_4 | (t) KrF_4 |
| (j) XeF_4 | (u) BrF_3 |
| (k) SCl_6 | (v) SeF_4 |

(2) Draw a Lewis structure for each of the following ions and determine the formal charge on each atom.

- | | |
|----------------------------|------------------------|
| (a) OCN^- | (l) SiCl_5^- |
| (b) NH_4^+ | (m) BH_4^- |
| (c) H_3O^+ | (n) ClF_2^+ |
| (d) CO_3^{2-} | (o) ClF_4^+ |
| (e) BrF_2^+ | (p) SCN^- |
| (f) PCl_6^- | (q) AsF_6^- |
| (g) IF_4^- | (r) TeF_5^- |
| (h) XeF_5^+ | (s) BO_3^{3-} |
| (i) IF_4^+ | (t) ICl_4^- |
| (j) SF_5^+ | (u) KrF_3^+ |
| (k) XeF_3^+ | (v) PO_3^{3-} |

(3) Draw the VSEPR diagram for each of the molecules in questions 1. State the name of the shape. Give the hybridization of the central atom. Classify each as polar or non polar.

(4) Determine the VSEPR shape for each ion in question 2. Give the hybridization of the central atom.

Answers:

(1)

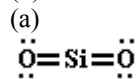

(b)

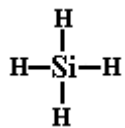

(c)

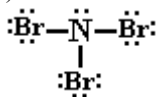

(d)

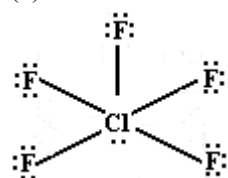

(e)

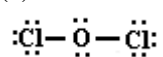

(f)

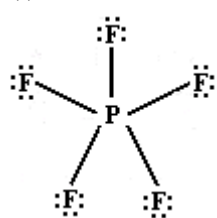

(g)

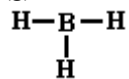

(h)

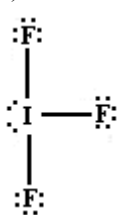

(i)

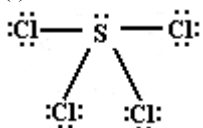

(j)

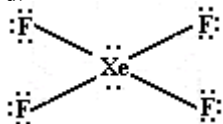

(k)

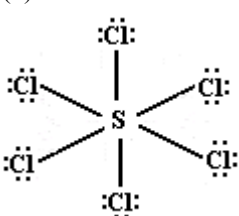

(l)

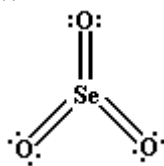

(m)

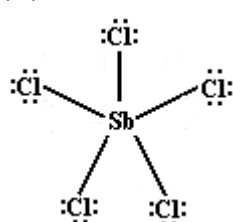

(n)

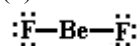

(o)

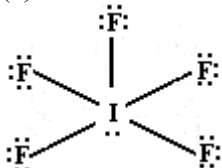

(p)

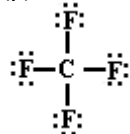

(q)

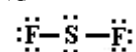

(r)

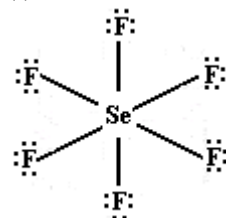

(s)

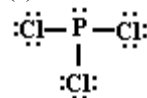

(t)

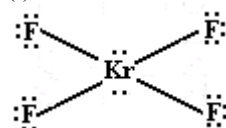

(u)

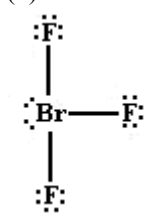

(v)

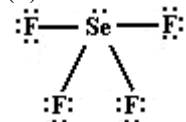

(2)

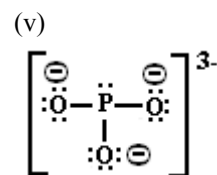
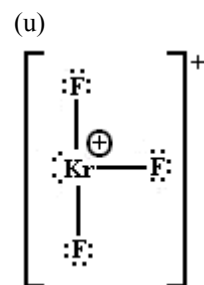
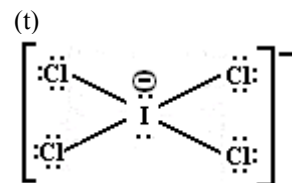
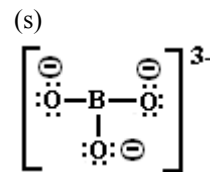
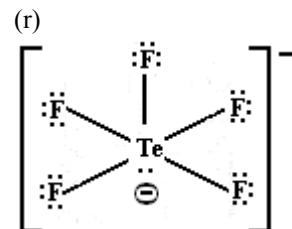
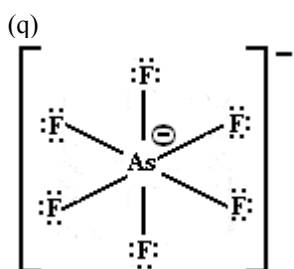
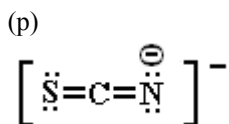
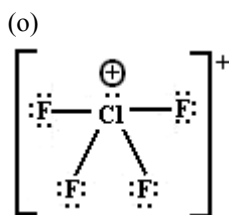
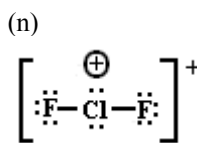
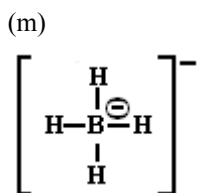
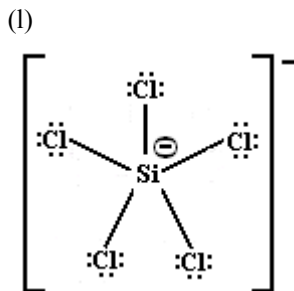
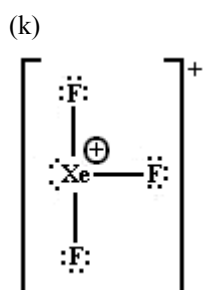
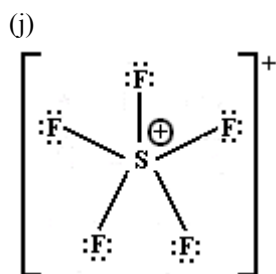
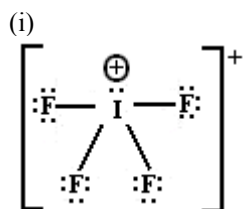
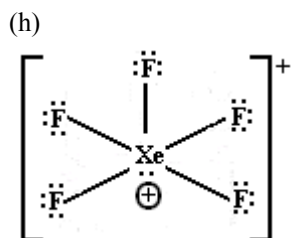
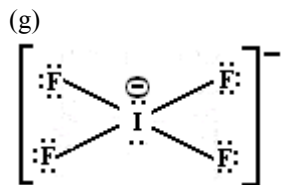
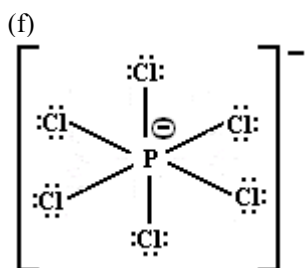
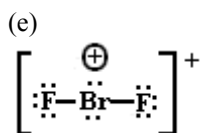
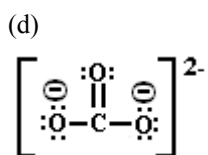
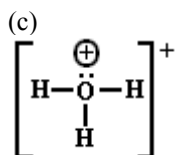
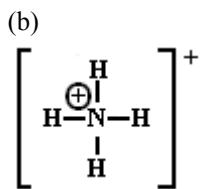
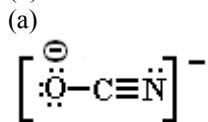

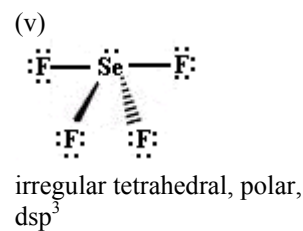
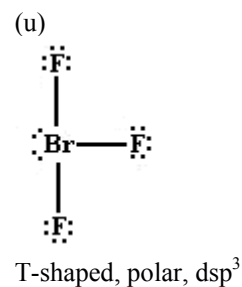
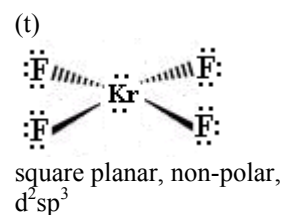
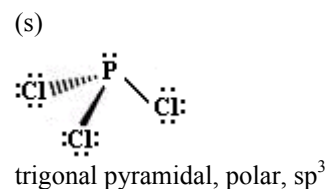
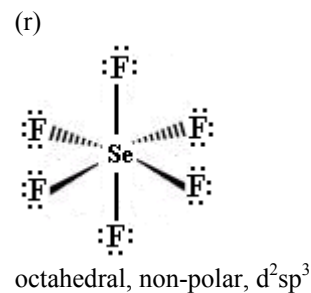
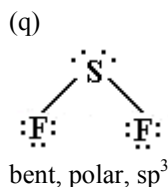
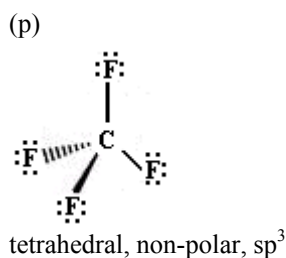
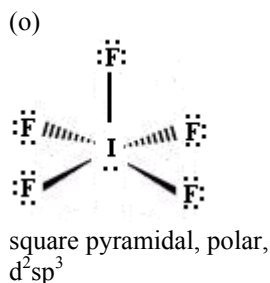
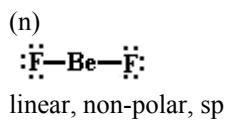
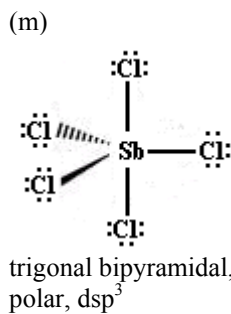
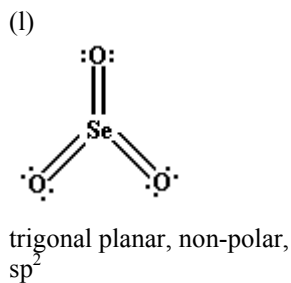
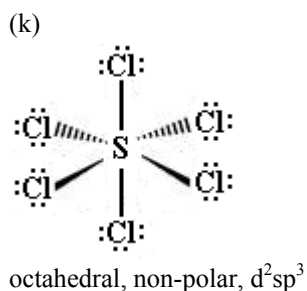
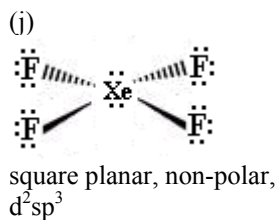
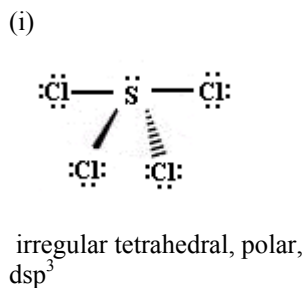
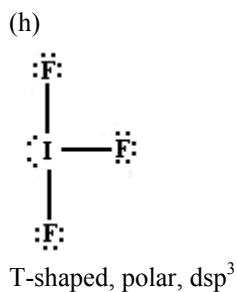
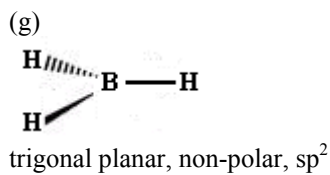
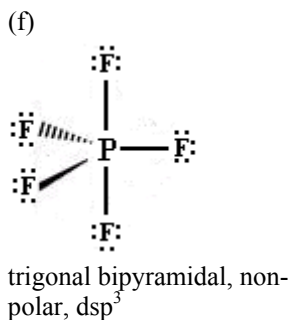
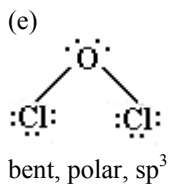
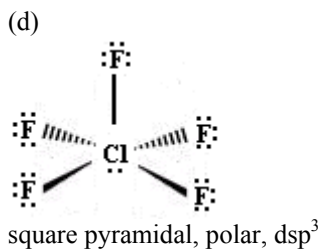
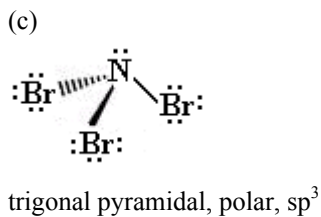
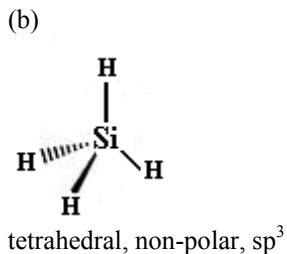
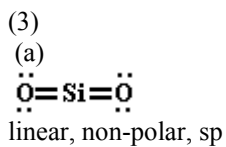

- (4) (a) linear, sp
 (d) trigonal planar, sp²
 (g) square planar, d²sp³
 (j) trigonal bipyramidal, dsp³
 (m) tetrahedral, sp³
 (p) linear, sp
 (s) trigonal planar, sp²

- (b) tetrahedral, sp³
 (e) bent, sp³
 (h) square pyramidal, d²sp³
 (k) T-shaped, dsp³
 (n) bent, sp³
 (q) octahedral, d²sp³
 (t) square planar, d²sp²

- (c) trigonal pyramidal, sp³
 (f) octahedral, d²sp³
 (i) irregular tetrahedral, dsp³
 (l) trigonal bipyramidal, dsp³
 (o) irregular tetrahedral, dsp³
 (r) square pyramidal, d²sp³
 (u) T-shaped, dsp³

(v) trigonal pyramidal, sp^3

(5)

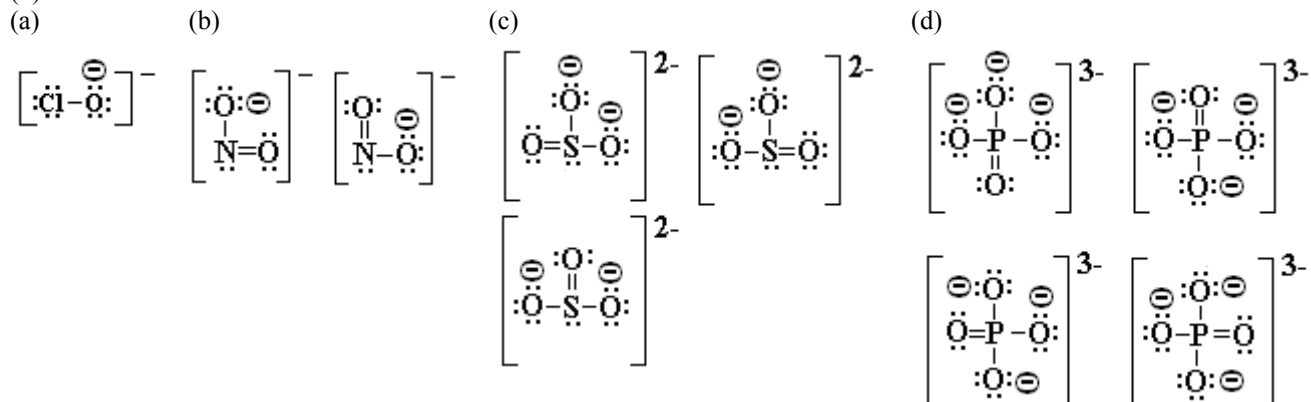

(6) 6 sigma and 2 pi

1: sp^3 , 2: sp , 3: sp

(7) 7 sigma and 1 pi

1: sp^3 , 2: sp^2 , 3: sp^3

(8) 9 sigma and 1 pi

1: sp^3 , 2: sp^3 , 3: sp^3

(9) In the compound calcium oxide, the ions each have a charge of two compared to the compounds sodium chloride and sodium bromide in which the ions each have a charge of one. The higher the charge on the ion, the larger the lattice energy of the compound. Since calcium oxide has the largest lattice energy, it has the highest melting point. In comparing sodium chloride and sodium bromide, the relative size of ions must be considered. The smaller the ion, the larger the lattice energy. Since the chloride ion is smaller than the bromide ion, sodium chloride has a higher lattice energy than sodium bromide. As a result, the melting point of sodium chloride is greater than the melting point of sodium bromide.

(10) Oxygen has valence electrons in the $n = 2$ energy level. Fluorine has valence electrons in the $n = 2$ energy level and chlorine has valence electrons in the $n = 3$ energy level. Since oxygen and fluorine have valence electrons in the same energy level, the orbital overlap between oxygen and fluorine will be greater than between oxygen and chlorine. As a result, the bond between oxygen and fluorine will be stronger (ie. higher in energy) and shorter than the bond between oxygen and chlorine.

(11)

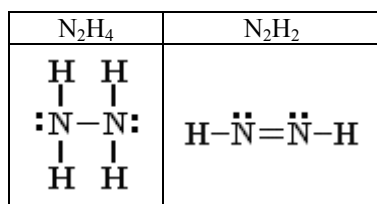

The nitrogen-nitrogen bond in N_2H_2 would be stronger (higher in energy) than the bond in N_2H_4 because it is a double bond rather than a single bond. The nitrogen-nitrogen bond in N_2H_2 would also be shorter than the bond in N_2H_4 .

Name: _____

Period: _____

Intermolecular Bonds

(1) Identify all of the intermolecular bonds present in each substance by placing an "X" in the appropriate column(s).

Substance	London Dispersion Forces	Dipole Interactions	Hydrogen Bonding
H ₂ O			
PCl ₃			
C ₃ H ₈			
CO ₂			
NH ₃			
He			
CH ₃ Cl			
SF ₄			
I ₂			
CH ₄			
CH ₃ OH			
N ₂			
CH ₃ NH ₂			
CO			
N ₂ H ₂			
C ₂ H ₂			
XeF ₄			
AsH ₃			
NO			
HCN			

(2) Complete the following table. Explain the relative boiling points/heats of vapourization in terms of intermolecular forces. Which substance would be the most soluble in water?

Molecule	Structure	Intermolecular Bonds	Boiling Point	H _{vap}
Ethane	<pre> H H H-C-C-H H H </pre>		-183 °C	14 kJ/mol
Ethanol	<pre> H H H-C-C-O-H H H </pre>		78 °C	39 kJ/mol
Chloroethane	<pre> H H H-C-C-Cl H H </pre>		12 °C	26 kJ/mol

Answers:

(1)

Substance	London Dispersion Forces	Dipole Interactions	Hydrogen Bonding
H ₂ O	X	X	X
PCl ₃	X	X	
C ₃ H ₈	X		
CO ₂	X		
NH ₃	X	X	
He	X		
CH ₃ Cl	X	X	
SF ₄	X	X	
I ₂	X		
CH ₄	X		
CH ₃ OH	X	X	X
N ₂	X		
CH ₃ NH ₃	X	X	X
CO	X	X	
N ₂ H ₂	X	X	X
C ₂ H ₂	X		
XeF ₄	X		
AsH ₃	X	X	
NO	X	X	
HCN	X	X	

(2) Ethane: London dispersion forces; Ethanol: London dispersion forces, dipole interactions, and hydrogen bonding. Chloroethane: London dispersion forces and dipole interactions. Ethane has the lowest boiling point because the molecules are held together only by London dispersion forces, the weakest type of intermolecular bonds, which are easily broken. Chloroethane has an intermediate boiling point as the molecules are held together by both London dispersion forces and dipole interactions. The dipole interactions result in stronger intermolecular bonds. Ethanol has the highest boiling point as the molecules participate in hydrogen bonding, the strongest type of intermolecular bond.

Ethane has the weakest intermolecular forces and therefore has the lowest heat of vapourization. Ethanol has the strongest intermolecular forces and therefore has the largest heat of vapourization. Chloroethane has moderate strength of intermolecular bonds and therefore has an intermediate value for heat of vapourization.

Ethanol would be the most soluble in water since it has the capacity to form hydrogen bonds with water molecules. None of the other molecules would be able to form hydrogen bonds with water, so they would be less soluble.